

# RC5501

## 4 Watt Stereo Sound Driver

### Features

- Up to 4W/channel
- Drives 8Ω and 4Ω non-powered speakers
- NO-POP during power-up/power-down and mute
- Internal thermal limiting circuitry
- Total Harmonic Distortion < 0.1%

### Applications

- Multimedia PC motherboards and add-in sound cards
- Companion chip to sigma-delta sound codecs
- Sound Channel back-end in set-top boxes

### Description

The RC5501 is a stereo power amplifier used for directly powering speaker and headphone sets.

### Block Diagram

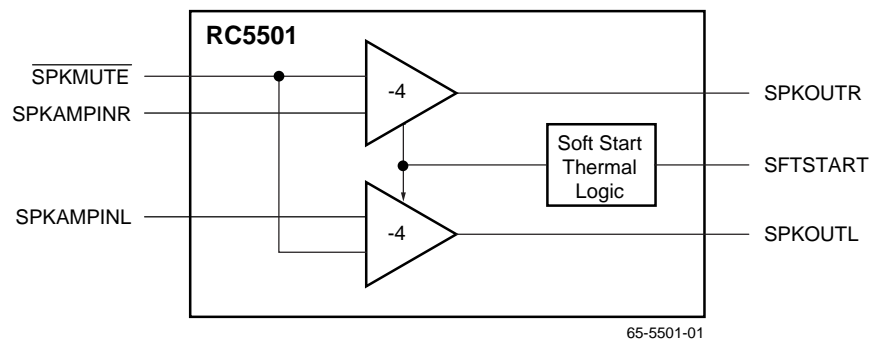

## Functional Description

The RC5501 stereo sound driver is an audio device that can be used on PC motherboards and add-in sound cards. It consists of stereo output drivers for headphone or speakers with a mute feature and circuitry that eliminates popping at power on, power off, mute enable, and mute disable.

The output drivers can deliver up to 2 Watts peak and 4 Watts peak into 8Ω and 4Ω speakers, respectively, from a 12V source. The drivers use class AB amplifiers and maintain a

low bias current. To help prevent turn-on speaker pop, a delay is provided to these output drivers to allow settling before speaker activation. The time constant is user-defined through an external capacitor (CDELAY) on the SFTSTART pin.

The thermal limiting circuitry activates if the chip temperature typically exceeds 150°C.

## Pin Assignments

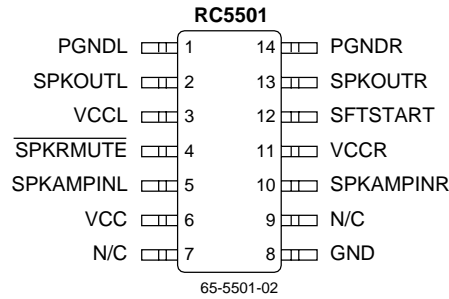

## Pin Definitions

Pin Name	Pin Number	Pin Function Description
PGNDL	1	Left speaker ground.
SPKOUTL	2	Left speaker output.
VCCL	3	Left speaker 12V power supply.
SPKRMUTE	4	Speaker mute.
SPKAMPINL	5	Left channel power amp input.
VCC	6	12V power supply input.
N/C	7, 9	No connection.
GND	8	Ground.
SPKAMPINR	10	Right channel power amp input.
VCCR	11	Right speaker 12V power supply.
SFTSTART	12	Soft start timing capacitor.
SPKOUTR	13	Right speaker output.
PGNDR	14	Right speaker ground.

## Absolute Maximum Ratings

(beyond which the device may be damaged)<sup>1</sup>

Parameter		Min	Typ	Max	Units
VCC VCCR VCCL	Power supply voltage			13.2	V

### Note:

- Functional operation under any of these conditions is NOT implied. Performance is guaranteed only if Operating Conditions are not exceeded.

## Operating Conditions

Parameter		Conditions	Min	Typ	Max	Units
VCC VCCL VCCR	Power Supply		11.2	12	12.8	V
V <sub>IH</sub>	Input Voltage Logic High		2			V
V <sub>IL</sub>	Input Voltage Logic Low				0.8	V
	Ambient Temperature		0		70	°C
T <sub>c</sub>	Maximum Operation Die Temperature	Overthermal Protection		150		°C
I <sub>total</sub>	Power Supply Current	No load		19	25	mA
ESD	ESD Threshold	Human Body Model	2000			V

## Electrical Characteristics

VCC = VCCL = VCCR = 12V ± 6%, unless otherwise specified.

Parameter		Conditions	Min	Typ	Max	Units
<b>Speaker Driver</b>		f = 1KHz, RL = 8Ω unless otherwise specified				
Z <sub>in</sub>	Input Impedance		100			KΩ
A <sub>v</sub>	Voltage Gain	V <sub>in</sub> = 0.5 V <sub>rms</sub>	-3.80	-4.0	-4.20	V/V
L&R A <sub>v</sub>	Left and Right Gain Matching	V <sub>out</sub> = 4V <sub>p-p</sub>		0.5		%
V <sub>o</sub>	Output Voltage	RL = 4Ω or 8Ω, VCC = 12V		±4		V
SNR	Signal to Noise Ratio	Input Referenced		85		dB
P <sub>o</sub>	Power Output Per Channel Peak	RL = 4Ω, VCC = 12V (See Figure 1)		4		W
CS	Channel Separation L/R Input Referenced	V <sub>in</sub> = 0.5 V <sub>rms</sub>	66			dB
THD	Total Harmonic Distortion	f <sub>o</sub> = 1KHz, P <sub>o</sub> = 50mW		0.1		%
Noise		20Hz to 20kHz, A-Weighted		4		μV <sub>rms</sub>
PSRR	Power Supply Rejection Ratio Input Referenced	f = 100Hz, ΔV <sub>cc</sub> = 1.6V <sub>p-p</sub>	70	80		dB
<b>Soft Start</b>						
Delay	Anti-Pop Ramp-Up and Ramp-Down time	No Pop condition C <sub>DELAY</sub> = 22μF on SFTSTART		2		sec

# Applications Discussion

Preliminary Information

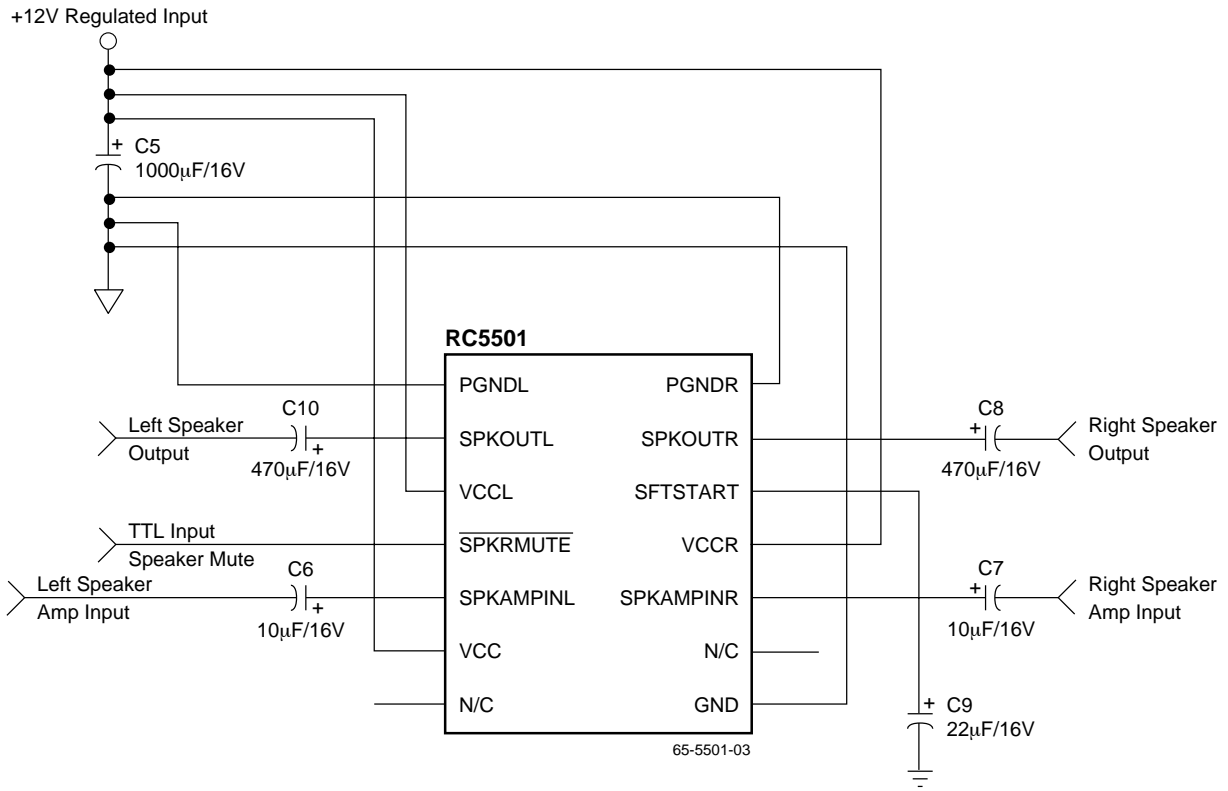

**Notes:**

1. 4 watt power represents the peak of the audio level and cannot be sustained without correct package thermal considerations. The average audio signal can be sustained by the RC5501 without extra thermal considerations.
2. To improve the thermal resistance of the PDIP package, a heat sink can be used.

**Figure 1. 4 Ohm Speaker, 4 Watt Application or 8 Ohm Speaker, 2 Watt application**

**Notes:**

Preliminary Information

**Notes:**

Preliminary Information

# Mechanical Dimensions

## 14 Lead Plastic DIP Package

Symbol	Inches		Millimeters		Notes
	Min.	Max.	Min.	Max.	
A	—	.210	—	5.33	
A1	.015	—	.38	—	
A2	.115	.195	2.93	4.95	
B	.014	.022	.36	.56	
B1	.045	.070	1.14	1.78	
C	.008	.015	.20	.38	4
D	.725	.795	18.42	20.19	2
D1	.005	—	.13	—	
E	.300	.325	7.62	8.26	
E1	.240	.280	6.10	7.11	2
e	.100 BSC		2.54 BSC		
eB	—	.430	—	10.92	
L	.115	.200	2.92	5.08	
N	14		14		5

**Notes:**

1. Dimensioning and tolerancing per ANSI Y14.5M-1982.
2. "D" and "E1" do not include mold flashing. Mold flash or protrusions shall not exceed .010 inch (0.25mm).
3. Terminal numbers are shown for reference only.
4. "C" dimension does not include solder finish thickness.
5. Symbol "N" is the maximum number of terminals.

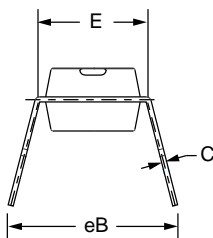
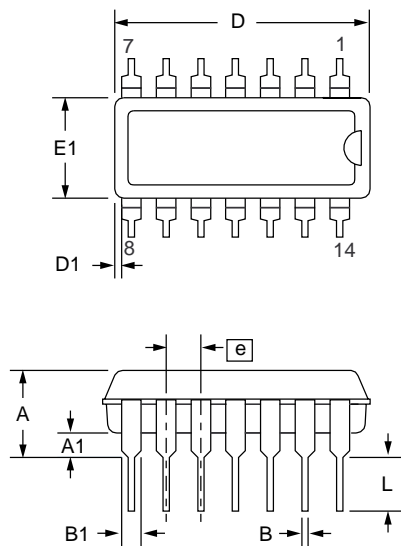

Preliminary Information

## Ordering Information

Product Number	Package
RC5501N	14 PDIP

Preliminary Information

### LIFE SUPPORT POLICY

FAIRCHILD'S PRODUCTS ARE NOT AUTHORIZED FOR USE AS CRITICAL COMPONENTS IN LIFE SUPPORT DEVICES OR SYSTEMS WITHOUT THE EXPRESS WRITTEN APPROVAL OF THE PRESIDENT OF FAIRCHILD SEMICONDUCTOR CORPORATION. As used herein:

1. Life support devices or systems are devices or systems which, (a) are intended for surgical implant into the body, or (b) support or sustain life, and (c) whose failure to perform when properly used in accordance with instructions for use provided in the labeling, can be reasonably expected to result in a significant injury of the user.
2. A critical component in any component of a life support device or system whose failure to perform can be reasonably expected to cause the failure of the life support device or system, or to affect its safety or effectiveness.